

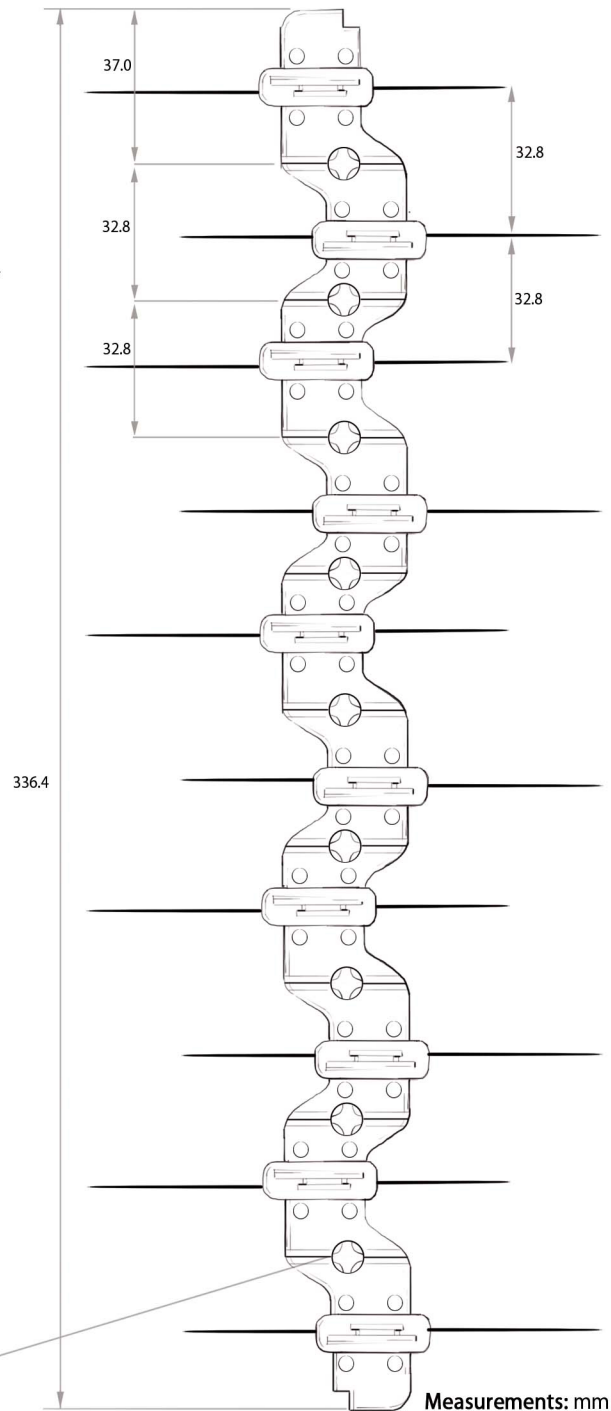

TECHNICAL DATA SHEET

Defender Gull™ Stainless Steel Spike (Product Code: BIRD0025)

The base of this product is manufactured from high quality, ultra violet (UV) stabilised polycarbonate (resin product code LEXAN 123R) Temperature resistance with no loss of mechanical strength at 130°C. The protruding pins are manufactured from 304 grade stainless steel and have a tensile strength of 1600/mm. The pins are 150 mm in length and have a diameter of approximately 1.42 mm. All pins protrude from the base which is 336.4 mm in length. Angles and spacing of pins can be determined from the below diagrams.

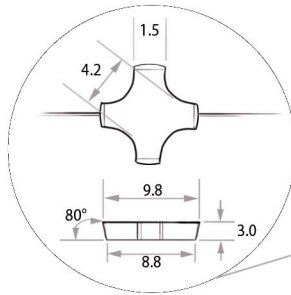
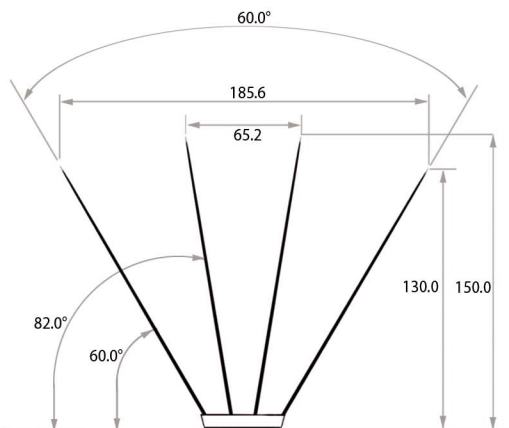
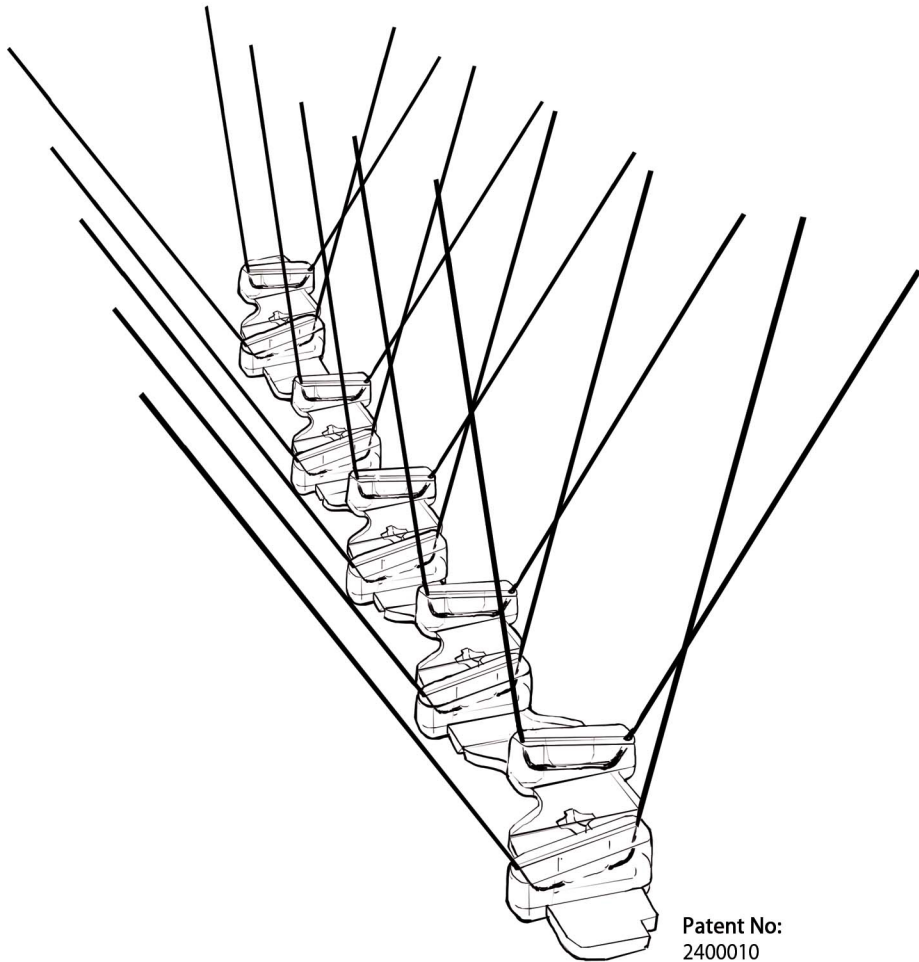

Measurements: mm

KEY FEATURES

4 Rows of Pins

The Defender Seagull Spike has 6 inch (150mm) long stainless steel pins protruding from the base of the spike to stop seagulls. The design helps prevent seagulls walking or landing on your property.

Silicone Fixing Holes

Along the base are 9 cross shaped holes. When the spikes are pressed onto a ledge the silicone oozes through the holes forming cross shaped rivets that lock the spike firmly in place. Screws or nails can be used as alternative to silicone.

Long Life Expectancy

A 3mm thick UV stabilised base ensures that this spike will be around a lot longer than most other spikes. This product carries a 25 year "No Rust" warranty.

Snaps in to Sections

Along the base of the spike are 9 breakable sections that can be simply snapped apart with your fingers.